

All-Ceramic Capacitor Step-Down/Inverter Supplies +/-5V at 3A

A MAX8538 dual synchronous buck controller supplies both +5V and -5V outputs at 3A. One controller operates as a synchronous rectified step-down (buck) converter while the second controller runs a transformer driven inverter. The circuit also features soft start and soft stop.

This 1MHz all-ceramic capacitor design uses the MAX8538 dual synchronous buck controller to provide soft-start and soft-stop functions for the +5V and -5V rails at the same time. One controller output is configured as a synchronous buck converter to provide +5V @ 3A. The second buck controller is configured as a flyback inverter with a 1:1 transformer to provide -5V @ 3A.

The negative output voltage is controlled by a MAX4400 op-amp with an inverting gain of one-half. The op-amp is biased from the MAX8538's on-board 5V VL regulator. With the gain of -1/2 the op-amp output is within its range and within the common-mode range of the error amp.

The control gain of a buck converter is $V_{out} / V_{in} = \text{duty cycle}$. The control gain of a 1:1 flyback inverter is $V_{out} / V_{in} = \text{duty cycle} / (1 - \text{duty cycle})$, which increases with duty cycle. For a 1:1 flyback inverter, $\text{duty cycle} = V_{out} / (V_{in} + V_{out}) = 5V / (10.8V + 5V) = 0.317$. Then the extra control gain is $1 / (1 - 0.317) = 1.464$. This extra gain is factored into the design equations for Type 3 compensation by reducing the designed cross-over frequency a factor of 1.464. The op-amp inverting gain is compensated by adjusting R23 without affecting the rest of the compensation network.

A MAX837 voltage monitor provides under-voltage lockout. The MAX8538 is turned on when V_{in} reaches 9.2V. R31 introduces 75mV of positive feedback (hysteresis) for noise-free switching to allow a clean soft-start and soft-stop with a low V_{in} slew-rate. Note that since the flyback inverter has discontinuous transformer current, getting the -5V soft-stop to be symmetric with the +5V rail will depend on the load on the -5V rail. Also the -5V side's discontinuous transformer current requires larger output filter capacitance than the +5V side.

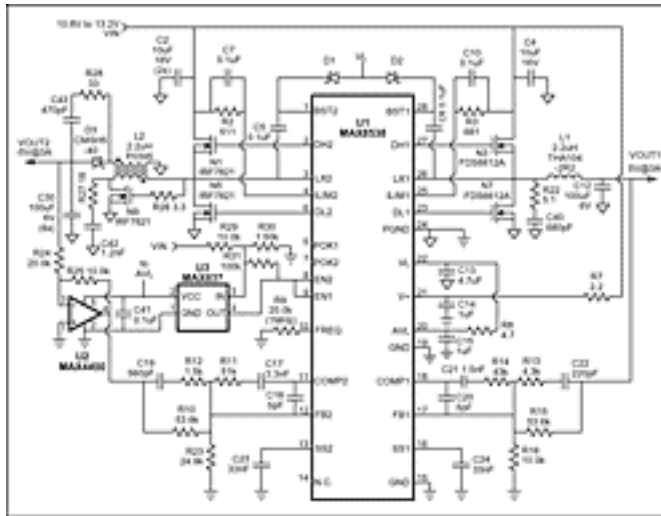

[For Larger Image](#)

Figure 1.

Table 1.

Vin	Iin	V1	I1	V2	I2	Efficiency
12.00	0.044	5.083	0	-5.043	0	
10.77	3.41	5.078	3	-5.038	3	0.826
12.00	3.06	5.080	3	-5.040	3	0.827
13.23	2.79	5.080	3	-5.040	3	0.823
		20mVpp ripple in 20MHz BW		25mVpp ripple in 20MHz BW		

Table 2. BILL OF MATERIALS 10.8V to 13.2V Input -5V @ 3A, 5V @ 3A Output 9/30/03

Designation	QTY	Description
C2,C4	3	10uF 16V X5R ceramic capacitor (1210) Taiyo Yuden EMK325BJ106MN
C5,C6,C7,C10, C41	5	0.1uF ceramic capacitor (0603)
C12,C30	7	100uF 6V Y5U ceramic capacitor (1210) Taiyo Yuden JMK325E107MM
C13	1	4.7uF 6V X5R ceramic capacitor (0805) Taiyo Yuden JMK212BJ475MG
C14	1	1uF 25V X5R ceramic capacitor (1206) Taiyo Yuden TMK316BJ105ML
C15	1	1uF 6V X5R ceramic capacitor (0603) Taiyo Yuden JMK107BJ105MA
C17	1	3.3nF ceramic capacitor (0603)
C18,C20	2	5pF ceramic capacitor (0603)

C19	1	560pF ceramic capacitor (0603)
C21	1	1.5nF ceramic capacitor (0603)
C22	1	220pF ceramic capacitor (0603)
C23,C24	2	33nF ceramic capacitor (0603)
C40	1	680pF ceramic capacitor (0603)
C42	1	1.2nF ceramic capacitor (0603)
C43	1	470pF ceramic capacitor (0603)
D1,D2	2	100mA 30V Schottky diode (SOD-323) Central Semi CMDSH-3
D3	1	5A 40V Schottky diode Central Semi CMSH5-40
L1	1	2.2uH 10A Power Inductor Delta THA104-2R2
L2	1	2.2uH 14.4A Dual Power Inductor Pulse P0395
N1,N5,N9	3	30V 13mOhm N-ch MOSFET (SO-8) International Rectifier IRF7821
N3,N7	2	30V 30mOhm N-ch MOSFET (SO-8) Fairchild FDS6612A
R2	1	511 Ohm 1% resistor (0603)
R3	1	681 Ohm 1% resistor (0603)
R7	1	2.2 Ohm 5% resistor (0603)
R8	1	4.7 Ohm 5% resistor (0603)
R9,R24	2	20.0k Ohm 1% resistor (0603)
R10,R15	2	53.6k Ohm 1% resistor (0603)
R11	1	51k Ohm 5% resistor (0603)
R12	1	1.5k Ohm 5% resistor (0603)
R13	1	4.3k Ohm 5% resistor (0603)
R14	1	43k Ohm 5% resistor (0603)
R16,R25	2	10.0k Ohm 1% resistor (0603)
R22	1	5.1Ohm 0.125W 5% resistor (1206)
R23	1	24.9k Ohm 1% resistor (0603)
R26	1	3.3 Ohm 0.25W 5% resistor (1210)
R27	1	18 Ohm 5% resistor (0603)
R28	1	33 Ohm 5% resistor (0603)
R29	1	10.0k Ohm 1% resistor (0603)
R30	1	1.50k Ohm 1% resistor (0603)
R31	1	100k Ohm 1% resistor (0603)
U1	1	MAX8538EEI (28-QSOP)
U2	1	MAX4400AXK (5-SC70)

More Information

MAX4400: [QuickView](#) -- [Full \(PDF\) Data Sheet](#) -- [Free Samples](#)

MAX837: [QuickView](#) -- [Full \(PDF\) Data Sheet](#) -- [Free Samples](#)

MAX8538: [QuickView](#) -- [Full \(PDF\) Data Sheet](#) -- [Free Samples](#)